

Eccentric Screw Pumps ALL-Optiflow SERIES AE1F

Design ID

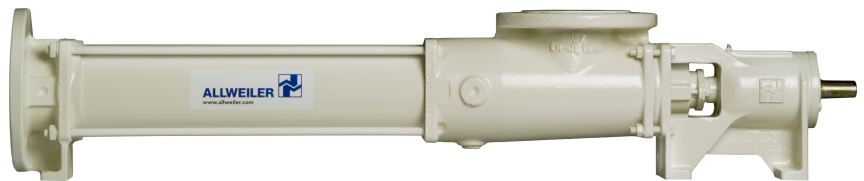

Application

For handling liquid to highly viscous, neutral or aggressive, uncontaminated or abrasive liquids, liquids containing gases or which tend to froth, also containing fibres and solid matter.

In waste water and waste water treatment engineering, chemical and petrochemical industry, paper and cellulose industry, soap and fats industry, paint and lacquer industry, food and beverage industry, plastics industry, ceramics industry, agriculture, sugar industry and in shipbuilding.

Function

Self-priming, single stage, rotary positive displacement pump. Conveying elements are the rotating eccentric screw (rotor) and the fixed stator. In the cross-sectional plane, both are in contact with one another at two points forming two sealing lines along the length of the conveying elements. The contents of the sealed chambers which are formed as the rotor turns are displaced axially and with complete continuity from the suction to the delivery end of the pump. Despite rotor rotation, there is no turbulence. The constant chamber volume excludes squeezing, thus ensuring an extremely gentle low-pulsating delivery.

Structural design

By external casing connecting screws (clamping screws), the pressure casing, stator and suction casing are interconnected. The suction casings are designed particularly favourable to flow. The pump sizes 403 to 5503 in cast iron design are provided with staggered holes for cleaning. The stator vulcanized into a tube is provided with external collars vulcanized to it on both sides reliably sealing towards the suction casing and delivery casing and protecting the stator shell from corrosion.

The exchangeable shaft sealing housing or mechanical seal housing (subsequent conversion to another sealing variant is possible) are arranged between the suction casing and bearing bracket. The sealing housings (shaft seals) are easily accessible as the complete bearing unit can be withdrawn from the driving shaft without any further pump dismounting.

Bearing of the driving spindle is effected in the bearing bracket. The torque of the drive is transmitted over the driving shaft and the joint shaft onto the rotor. On both sides, the joint shaft ends in liquid-tight encapsulated bolt joints, which are designed particularly simple and sturdy properly taking the eccentric movement of the rotor.

Shaft seal

By uncooled, cooled or heated stuffing box or by uncooled or cooled maintenance-free unbalanced, single or double-acting mechanical seal.

Material pairing and design are adapted to the respective operating conditions. For further data, refer to pages 3, 4.

The stuffing box or mechanical seal housings of the various shaft sealing types are interchangeable within one size. The various mechanical seal housing parts form a modular construction system and, in case of conversion to a different mechanical seal design, can be easily combined with one another.

Installation spaces for mechanical seals according to DIN EN 12 756 (except for double mechanical seal).

For further data, refer to pages 3, 4, 5 and 6.

Technical data

Deliveries, admissible speed ranges and required drive powers are to be taken from the performance graph on page 2 and/or the separate individual characteristic curves.

				AE1F
Delivery	Q	l/min	up to	3800
Temperature of fluid pumped	t	°C ①	up to	135
Delivery pressure				
single-stage	Δp	bar	up to	6
Pump outlet pressure	p_d	bar ③	up to	16
Attainable under pressure	p_s	bar ②	up to	0,95
Viscosity	η	mPas	up to	300.000
Admissible solids content	vol	%②	up to	60

The mentioned performance data are to be considered as a product and performance abstract only. The particular operating limits can be taken from the quotation or order acknowledgement.

Max. admissible grain sizes and fiber lengths

Size	103	203	403	553	703	1003
max. grain size	mm	3	3,8	5	6,8	9,5
max. fibre length	mm	42	48	60	79	98

Size	1603	3003	5503	
max. grain size	mm	9,5	14	20
max. fibre length	mm	98	130	210

Increasing solids content and increasing grain size require a reduction of the pump speed:

- ① depending upon the fluid to be pumped and the elastomers employed.
- ② depending upon the pump size/design, speed, fluid to be pumped.
- ③ depending on direction of rotation, inlet pressure.

Drive

Driving possibilities see page 11.

Drives of any manufacturers can be employed. For the technical data and dimensions, please refer to the documents of the manufacturers.

Installation

AE pumps may be installed horizontally or vertically, depending on the shaft seal. In case of vertical arrangement, "shaft shank downwards" is not admissible.

By means of a flexible coupling or via a gear (as a rule, V-belt drive), the pump and drive are connected with one another and mounted on a common base plate. For aggregate dimensions, please inquire.

Performance graph

For a rough selection of the pump size and speed as a function of the requested delivery and kind of fluid to be pumped. $V_{g,m}$ = available, mean sliding speed of the rotor in the stator.

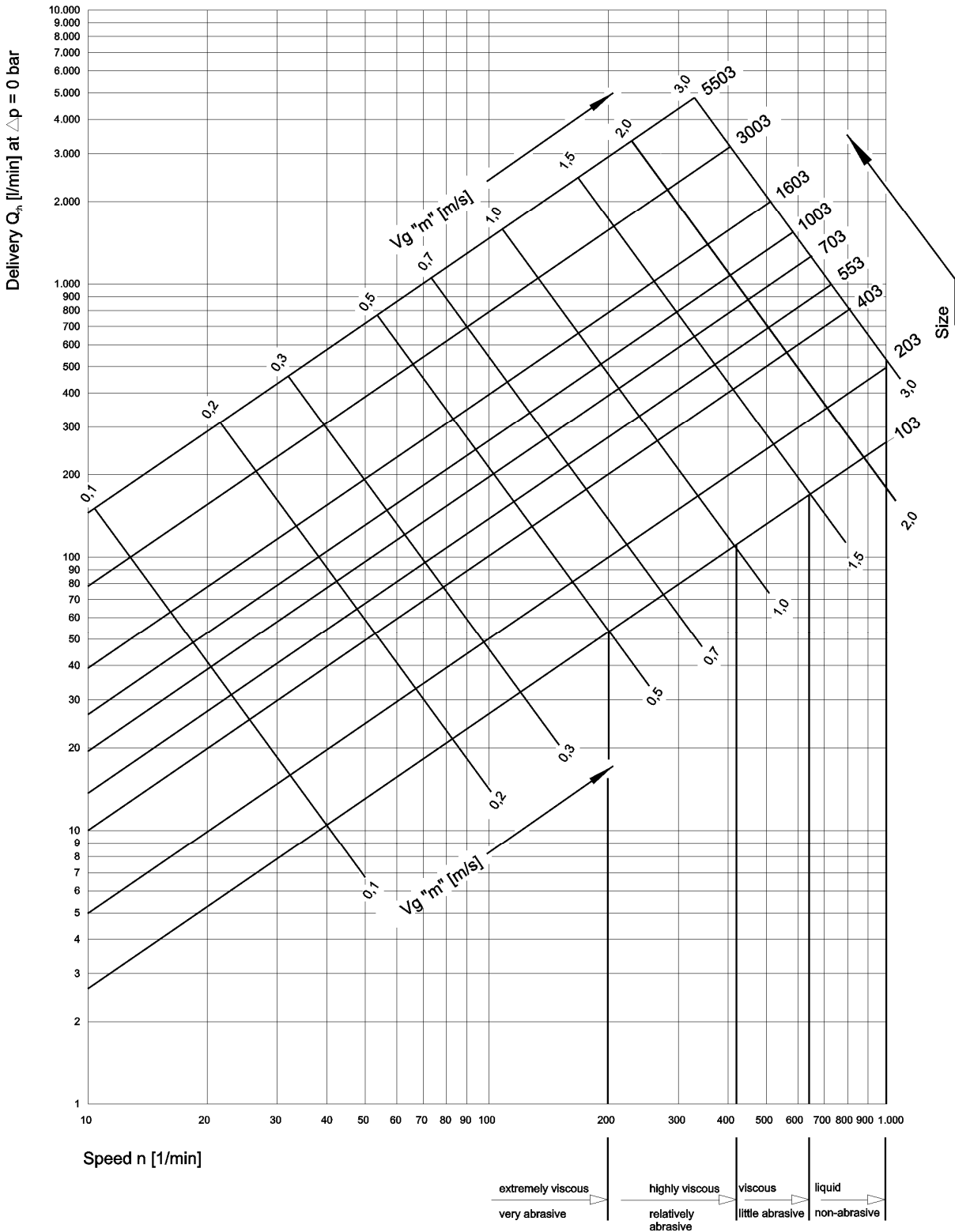

Sizes of series AE1F. Data on the performance range not covered by AE1F series are to be taken from the rear side of this brochure and/or the individual brochures of the other series.

For exact performance data, please refer to the individual characteristics.

Type code

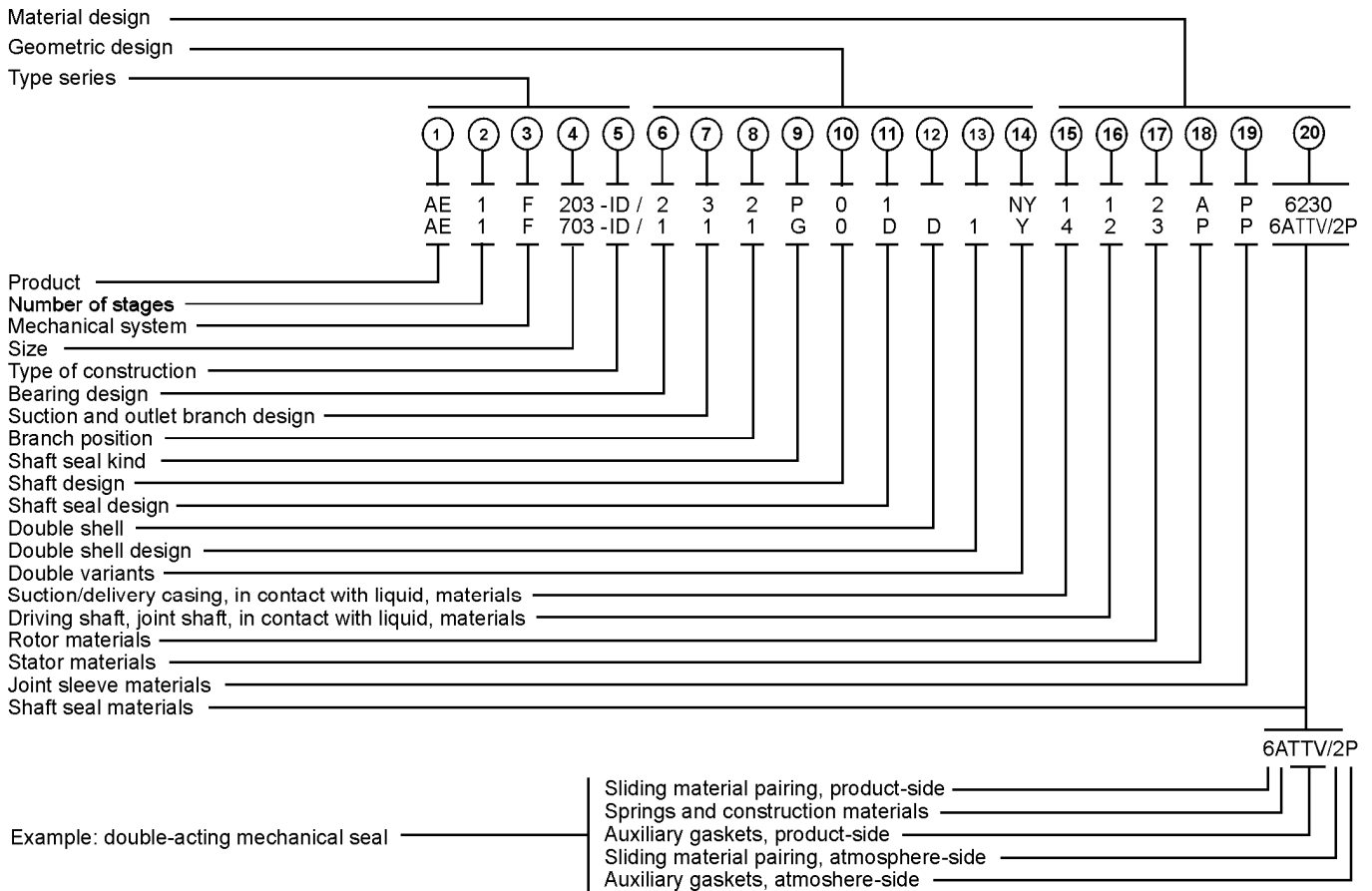

Explanations to the type code:

Position in type code	Designation	Design
①	Product	ALLWEILER eccentric screw pump
②	Number of stages	1 = single stage up to delivery pressure $\Delta p = 6$ bar
③	Mechanical system	F = rated for delivery pressure $\Delta p = 6$ bar
④	Size	Possible size series: 103, 203, 403, 553, 703, 1003, 1603, 3003, 5503. The numbers indicate the theoretic delivery in l/min with $n = 400$ 1/min and $\Delta p = 0$ bar.
⑤	Design	ID = Industrial design with internal bearing
⑥	Bearing design	1 = Hose-proof, radial bearing drive-side with sealing washer, axial bearing pump-side with shaft seal ring. Both bearings regreasable. For horizontal installation. 2 = Hose-proof, radial bearing on both sides with sealing washer, axial bearing pump-side with shaft seal-ring. Axial bearing regreasable, radial bearing lifetime-lubricated. For vertical installation with shaft shank upwards.
⑦	Suction- and discharge branch design	1 = DIN-flanges 3 = ANSI-flanges X = Suction and/or discharge branch special design } according to dimensional sheet, pages 8, 9
⑧	Branch position	1, 2, 3, 4 – For the arrangement please refer to the representation, page 8. Arrangement 3 for size 103 not possible.
⑨	Shaft seal type	P = Stuffing box or other non-mechanical shaft seal. G = Mechanical seal (mechanical shaft seal))
⑩	Shaft design	0 = Shaft without shaft sleeve 1 = Shaft with shaft sleeve (not possible with pump size 103)
⑪	Shaft seal design	Stuffing boxes P01/P11 = Stuffing box on normal design (without sealing chamber ring / without flushing ring) P02/P12 = Stuffing box with flushing ring P03/P13 = Stuffing box with internal sealing chamber ring P04/P14 = Stuffing box with external sealing chamber ring P0X/P1X = Non-mechanical shaft seal of special design

⑪	Shaft seal design (continued) X = design possible	Mechanical seals										
		for pump sizes		103	203	403	553	703	1003	1603	3003	5503
		Shaft diameter at the location of the shaft seal		25	30	35	43	43	53	53	60	75
		G0K/G1K = individual mechanical seal, DIN EN 12756, design K, shape U		①X	X	X	X	X	X	X	X	X
		G0N/G1N = as above, however design N		①X	X	X	X	X	X	X	X	X
		G0S/G1S = individual mechanical seal, DIN EN 12756, design K, shape U, rotating part with integrated locking device and pump-sided throttling ring		①X	X	X	X	X	X	X	X	X
		G0T/G1T = as above, however design N		①X	X	X	X	X	-	-	X	X
		G0Q/G1Q = individual mechanical seal, DIN EN 12756, design K, shape U with quench		①X	X	X	X	X	X	X	X	X
		G0D/G1D = double mechanical seal		①②	②	②	②	②	②	②	②	②
		G0X/G1X = mechanical seal of special design										
		① not available with shaft sleeve		② for gasket design, please inquire								
⑫	Double shell	D = Double shell for heating/cooling, available in stainless steel only Connections as threaded nipples for liquid media. Max. heating/cooling pressure 6 bar, max. heating temperature + 150°C, max. cooling temperature -40°C										
⑬	Double shell design	1 = Suction casing with double shell 2 = Stuffing box for P01/P11 with double shell 12 = Suction and shaft sealing housing P01/P11 double shell X = Special design for other double shells										
⑭	Design variants	Stator with uneven elastomer wall thickness (all qualities)										
		N M H T	Rotor temperature play as a function of the temperature of the fluid pumped									
		Y = Rotor ductile hard chromium-plated					W = Winding protection on joint shaft					
		Z = Rotor metallically coated					X = Other designs					
		S = Worm on joint shaft										
⑮	Suction and discharge casing in contact with fluid materials	1 = EN-GJL-250 3 = EN-GJL-250, inside H-rubberized 4 = 1.4408 A = 1.4462 X = Special materials										
⑯	Driving shaft, joint shaft in contact with liquid materials	1 = 1.4021/1.4571/1.1191 2 = 1.4301/1.4571 4 = 1.4571 A = 1.4462 X = Special materials, e. g. also for joint parts										
⑰	Rotor-materials	2 = 1.4301		4 = 1.4571		A = 1.4462						
		3 = 1.2436/1.2379		X = Special materials, e. g. other materials, plastic materials								
⑱	Stator-materials	PA = Acrylonitrile-butadiene rubbers (NBR)		P = Acrylonitrile-butadiene rubbers (NBR)		A = ALLDUR						
		HP = Acrylonitrile-butadiene rubbers, hydrated (HNBR)		E = EPDM								
		Y = Chlorosulfonated polyethylene (CSM)		X = Special materials								
⑲	Joint sleeve materials	P = Acrylonitrile-butadiene rubbers (NBR)		Y = Chlorosulfonated polyethylene (CSM)		X = Special materials						
		N = Polychloroprene		B = Butyl caoutchouc								
⑳	Shaft seal materials	Stuffing box: 5846 = Ramie fiber with PTFE impregnation, asbestos-free 6426 = Aramid-endless fiber with PTFE impregnation, asbestos-free 6230 = Graphite-incorporated PTFE with sliding agents, asbestos-free										
		Mechanical seal:										
		Sliding material pairing			Spring and construction materials			Auxiliary gaskets				
		1st point for single gasket 1st + 4th point for double gasket			2nd point			3rd point for single gasket 3rd + 5th points for double gasket				
		2 = CrMo cast iron/hard carbon 4 = Ceramics/hard carbon 5 = Hard metal/hard metal, highly wear-resistant 6 = Silicon carbide/silicon carbide highly wear-resistant, corrosion-resistant 7 = Silicon carbide/silicon carbide highly wear-resistant, highly corrosion-resistant X = Special materials			A = 1.4300 F = 1.4571 L = Hastelloy B M = Hastelloy C4 X = Special materials			P = Acrylonitrile-butadiene rubbers (NBR) ① double E = EP caoutchouc PTFE-coated S = Silicon caoutchouc N = Polychloroprene (N) V = Fluoroelastomer (FPM) TTE = EP caoutchouc ① TTV = Fluoroelastomer (FPM) ① TTS = Silicon caoutchouc ① X = Special materials				

Sectional drawing and component list

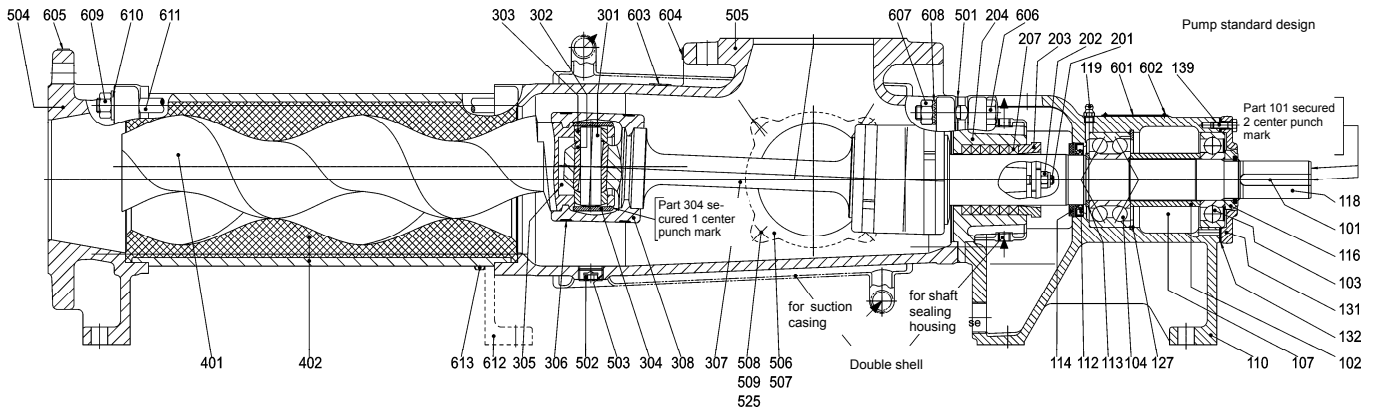

- Bearing 1:** Hose-proof, radial bearing drive-side with sealing washer; axial bearing pump-side with shaft seal ring. Both bearings regreasable. Only for horizontal installation.
- Shaft seal P01:** Due to particularly great packing length, versatile, admissible pressure at the shaft seal $p = -0,7$ to 16 bar.

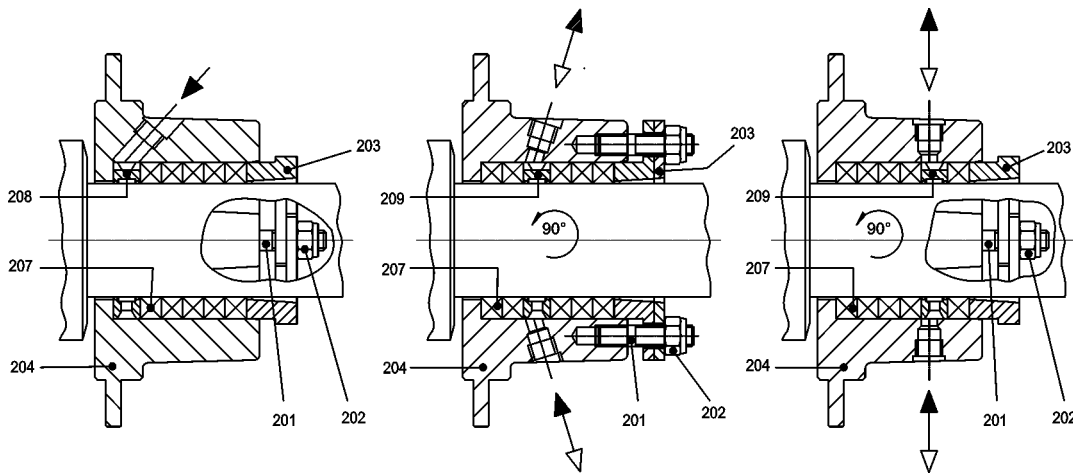

P02 Stuffing box with flushing ring

To be employed for very abrasive fluids pumped with external flushing,
 $p = -0,7$ to 12 bar

P03 Stuffing box with internal sealing chamber ring

To be employed for pure fluids with internal sealing or for abrasive fluids with external sealing,
 $p = -0,8$ to 6,0 bar

P04 Stuffing box with external sealing chamber ring

To be employed in case of incompatibility of the external sealing liquid with the fluid pumped or if air inlet is to be avoided,
 $p = -0,9$ to 12 bar

Part No.	Denomination
101	Key
102	Spacer sleeve
103	Groove ball bearing
104	Angular contact ball bearing
107	Bearing grease
110	Bearing bracket
112	Shaft seal ring
113	Spacer ring
114	Thrower
115	O-ring
116	Bearing nut
118	Driving shaft
119	Lubricating nipple

Part No.	Denomination
127	Circlip
129	Shim ring
131	Bearing cover
132	Gasket
139	Hexagon screw
201	Stud bolt
202	Self-locking nut
203	Gland half
204	Shaft sealing housing
206	Shaft sleeve
207	Stuffing box
208	Flushing ring
209	Sealing chamber ring

Part No.	Denomination
212	Screw plug
213	Joint tape
214	Mechanical seal housing
215	Mechanical seal cover
218	O-ring
219	Mechanical seal
220	Locking pin
232	Shaft seal ring
234	Throttling ring
235	O-ring
236	Locking pin
245	Hexagon screw
251	Sealing compound

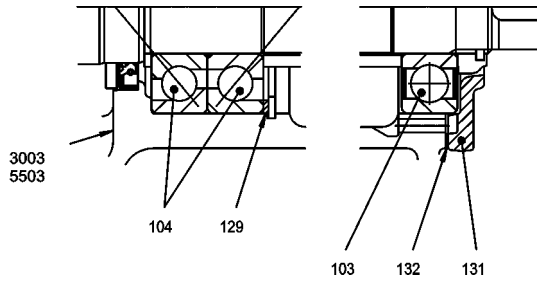

Bearing 1 for size 3003 and above
and 2: Axial bearing with two-single-row angular contact ball bearings

Radial bearing in case of bearing 2 (only for vertical installation with shaft shank upwards).

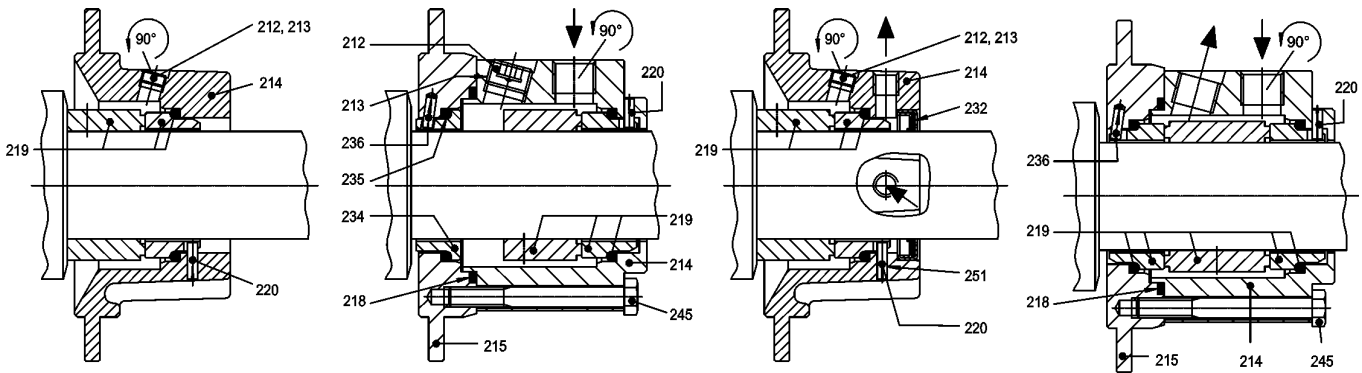

G0K/G0N Single mechanical seal, DIN EN 12 756, K/N design, U shape.
For employment, please inquire.
p = -0,5 bis 16 bar.

G0S/G0T Single mechanical seal, DIN EN 12 756, K/N design, U shape, rotating part with integrated locking device, with flushing liquid connection and pump-side throttling ring.
For employment, please inquire.
p = - 0.5 to 16 bar

G0Q Single mechanical seal, DIN EN 12 756, K design, U shape with quench.
For employment, please inquire.
p = - 0.5 to 16 bar

G0D Double mechanical seal, with sealing liquid connection.
For employment, please inquire.
p = - 0.95 to 16 bar

Part No.	Denomination
301	Joint bolt
302	Joint bush
303	Bush for joint bolt
304	Joint sleeve
305	Joint lubricant
306	Joint clamp
307	Joint shaft
308	Joint collar
401	Rotor
402	Stator
403	Stator gasket delivery-side
404	Stator gasket suction-side
501	Gasket for suction casing

Part No.	Denomination
502	Screw plug
503	Joint tape
504	Delivery casing
505	Suction casing
506	Suction casing cover
507	Gasket
508	Stud bolt
509	Hexagon nut
510	Fan-type lock washer
525	Washer
601	Type plate
602	Round head grooved pin
603	Information plate commissioning

Part No.	Denomination
604	Information plate suction
605	Information plate pressure
606	Hexagon screw/stud bolt
607	Hexagon nut
608	Fan-type lock washer
609	Hexagon nut
610	Washer
611	Clamp bolt
612	Support
613	Hexagon screw
627	Information plate physical hazard

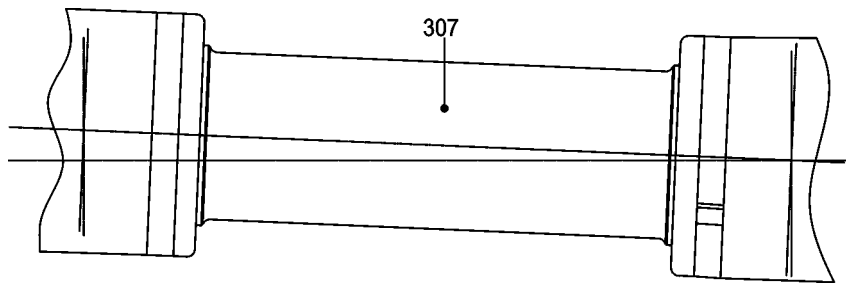

Winding protection on joint shaft

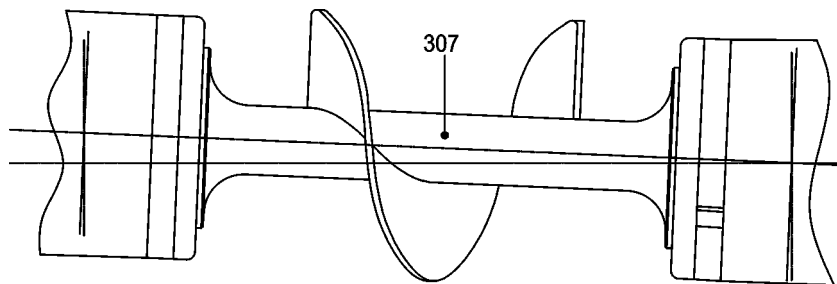

Worm on joint shaft

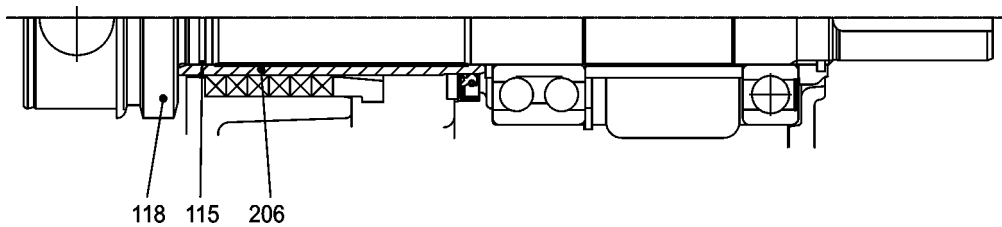

118 115 206

Shaft with shaft sleeve from size 203 and above
for all gasket designs possible

Pump dimensions, auxiliary connections, possible branch positions, weights
Suction casing with flange connection

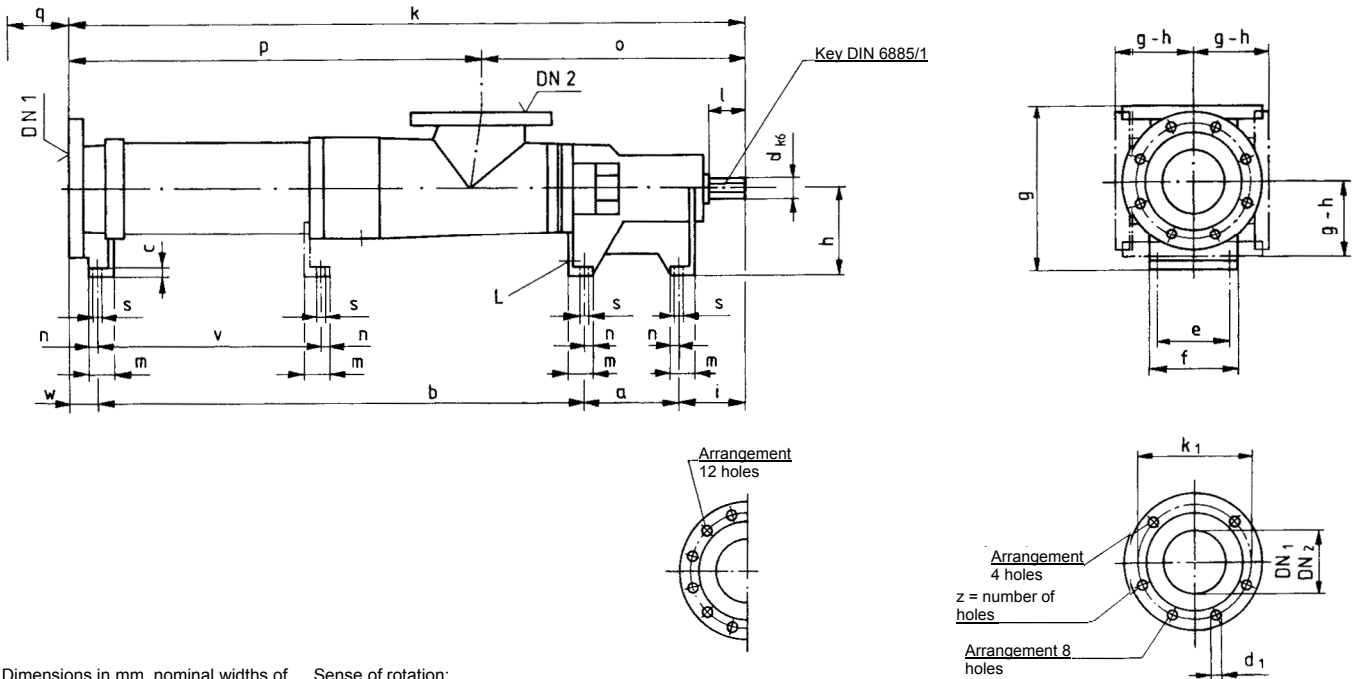

Dimensions in mm, nominal widths of ANSI flanges (DN) in inch. Subject to alternations

Sense of rotation: normally counterclockwise as seen from the driving side, here DN₁ = discharge branch, DN₂ = suction branch, change of sense of rotation possible, then, DN₁ = suction branch, DN₂ = discharge branch

Series Size	Pump dimensions																max. mass kg
	a	b	c	d	e	f	h	i	l	m	n	o	q ^①	s	L	v	
AE 1F 0103-ID	114	585	10	18	75	95	90	65	30	30	11	278	280	9	Rp 3/8	-	28
AE 1F 0203-ID	122	711	10	22	85	105	100	79	40	30	11	316	365	9	Rp 3/8	-	42
AE 1F 0403-ID	140	897	13	28	100	125	125	95	50	38	13	378	470	11,5	Rp 1/2	-	65
AE 1F 0553-ID	151	923	15	32	114	140	140	106	60	40	14	422	430	14	Rp 3/4	-	85
AE 1F 0703-ID	151	1075	15	32	114	140	140	106	60	40	14	422	580	14	Rp 3/4	-	93
AE 1F 1003-ID	171	1071	16	42	132	168	160	118	65	50	19	492	490	18	Rp 3/4	-	132
AE 1F 1603-ID	171	1359	16	42	132	168	160	118	65	50	19	492	780	18	Rp 3/4	-	157
AE 1F 3003-ID	190	1679	16	48	164	200	180	130	75	50	19	546	980	18	Rp 3/4	1079	272
AE 1F 5503-ID	220	2042	21	60	200	245	225	158	90	63	23	669	1200	22	Rp 1	1313	495

① Stator dismantling dimension

Possible branch positions as seen from the drive

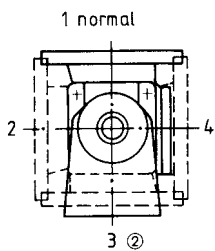

② for size 103 not possible

Flange dimensions

DIN EN 1092, PN 16 ⑤				ANSI B16.1/16.5, Class 125/150 ④			
DN ₁ /DN ₂	k ₁	d ₁	z	DN ₁ /DN ₂	k ₁	d ₁	z
50	125	18	4	2	120,6	19	4
65	145	18	4	2 1/2	139,7	19	4
80	160	18	8	3	152,4	19	4
100	180	18	8	4	190,5	19	8
125	210	18	8	5	215,9	22,2	8
150	240	22	8	6	241,3	22,2	8
200	295	22	12	8	298,4	22,2	8
250	355	26	12	10	361,9	25,4	12
300	410	26	12	12	431,8	25,4	12

Series Size	Connection dimensions for suction and discharge branch																	
	Flanges DIN EN 1092, PN 16 ⑤						Flanges ANSI B16.1, Class 125 ④						Flanges ANSI B16.5, Class 150 ④					
	DN ₁	DN ₂	③ k	③ p	③ w	③ g	DN ₁	DN ₂	③ k	③ p	③ w	③ g	DN ₁	DN ₂	k	p	w	g
AE 1F 0103-ID	50	50	807	529	43	175	2	2	803	525	39	171	2	2	807	529	43	175
AE 1F 0203-ID	65	65	958	642	46	190	2 ½	2 ½	957	641	45	189	2 ½	2 ½	962	646	50	194
AE 1F 0403-ID	80	80	1177	799	45	230	3	3	1175	797	43	228	3	3	1180	802	48	233
AE 1F 0553-ID	100	100	1224	802	44	260	4	4	1226	804	46	262	4	4	1226	804	46	262
AE 1F 0703-ID	100	100	1376	954	44	260	4	4	1378	956	46	262	4	4	1378	956	46	262
AE 1F 1003-ID	125	125	1404	912	44	300	5	5	1404	912	44	300	5	5	1404	912	44	300
AE 1F 1603-ID	125	125	1692	1200	44	300	5	5	1692	1200	44	300	5	5	1692	1200	44	300
AE 1F 3003-ID	150	150	2058	1512	59	350	6	6	2058	1512	59	350	6	6	2058	1512	59	350
AE 1F 5503-ID	200	200	2484	1815	64	425	8	8	2484	1815	64	425	8	8	2484	1815	64	425

③ for rubber-coating + 3 mm

⑤ Connecting dimensions acc. DIN EN 1092, up to DN100 raised face form B, greater than DN100 raised form A

④ Sealing surface: stock finish

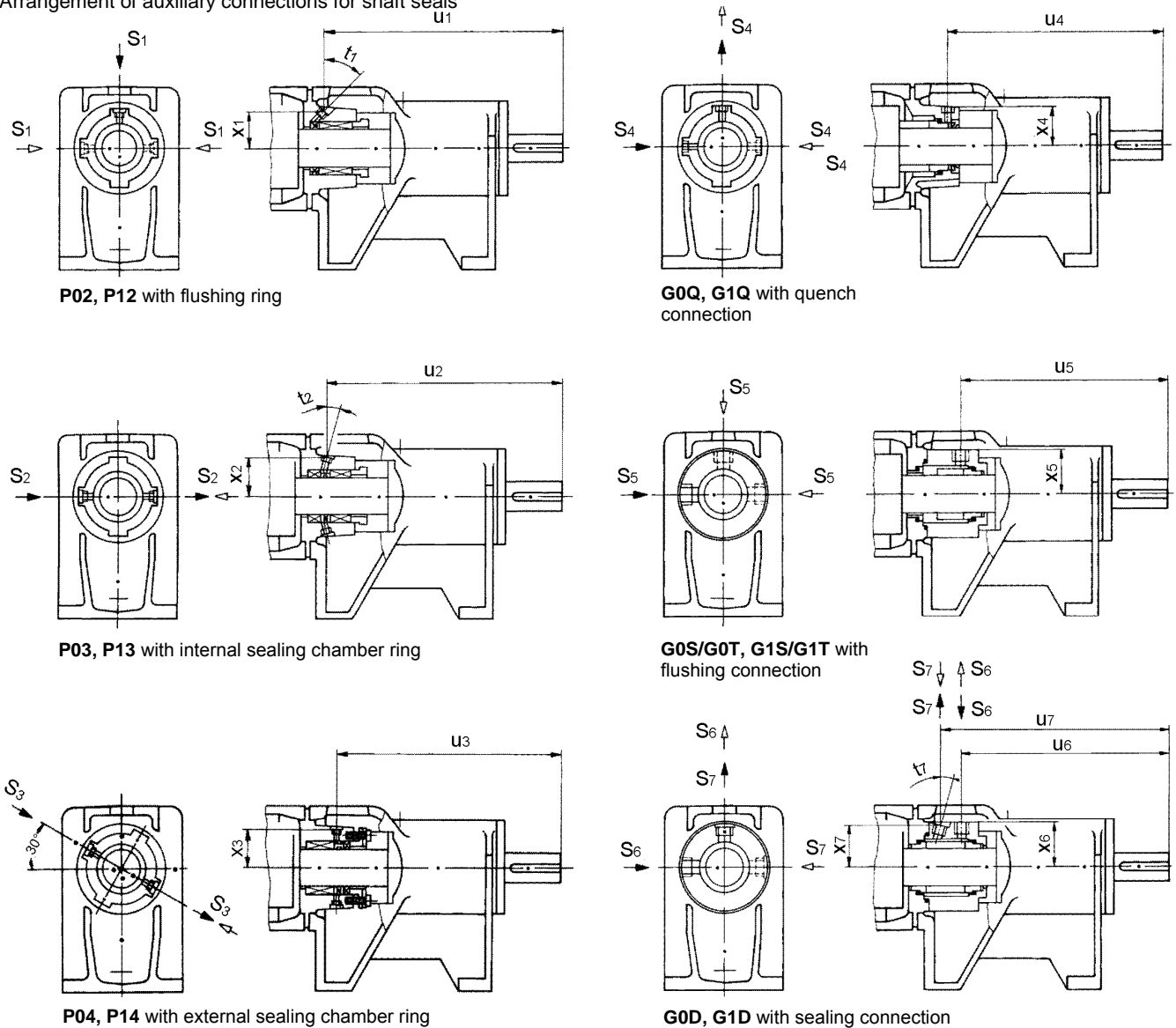
Arrangement of auxiliary connections for shaft seals

Series Size	Connection dimensions auxiliary connections for shaft seals											
	P02, P12 with flushing ring				P03, P13 with internal sealing chamber ring				P04, P14 with external sealing chamber ring			
	S ₁ ⊕	u ₁	x ₁	t ₁	S ₂ ⊕	u ₂	x ₂	t ₂	S ₃ ⊕	u ₃	x ₃	
AE 1F 103-ID	M 8 x 1	195,5	28	42°	M 8 x 1	188	30	20°	M 8 x 1	180,5	30,5	
AE 1F 203-ID	M 8 x 1	217	31,5	40°	M 8 x 1	211	32	20°	M 8 x 1	202,5	33,5	
AE 1F 403-ID	Rp ⅝	255	38	42°	Rp ⅝	248	40	17°	Rp ⅝	236	39,5	
AE 1F 553-ID	Rp ⅝	279	42	42°	Rp ⅝	272	44	17°	Rp ⅝	261	43,5	
AE 1F 703-ID	Rp ⅝	316	52	42°	Rp ⅝	307	54	17°	Rp ⅝	292,5	54,5	
AE 1F 1003-ID	Rp ⅝	349	56	35°	Rp ⅝	338,5	57	13°	Rp ⅝	322,5	58	
AE 1F 1603-ID	Rp ⅝	416	67	35°	Rp ⅝	403	68,5	13°	Rp ⅝	383	69,5	

Series Size	Connection dimensions auxiliary connections for shaft seals													
	G0S/G0T, G1S/G1T with flushing connection			G0Q, G1Q with quench connection			G0D, G1D with sealing connection							
	S ₅ ⊕	u ₅	x ₅	S ₄ ⊕	u ₄	x ₄	S ₆ ⊕	S ₇ ⊕	u ₆	u ₇	x ₆	x ₇	t ₇	
AE 1F 103-ID	Rp ¼	157	34	Rp ⅝	167	30,5	Rp ¼	Rp ¼	157	182,5	34	33	15°	
AE 1F 203-ID	Rp ¼	179	38	Rp ⅝	187,5	30,5	Rp ¼	Rp ¼	179	204,5	38	36,5	15°	
AE 1F 403-ID	Rp ¼	220,5	41,5	Rp ⅝	230	33,5	Rp ¼	Rp ¼	220,5	245,5	41,5	40	15°	
AE 1F 553-ID	Rp ⅝	241	48,5	Rp ⅝	255	41	Rp ⅝	Rp ⅝	241	266	48,5	47	15°	
AE 1F 703-ID	Rp ⅝	280	56	Rp ⅝	287	54	Rp ⅝	Rp ⅝	280	305,5	56	53,5	20°	
AE 1F 1003-ID	Rp ⅝	297	61	Rp ⅝	315,5	57,5	Rp ⅝	Rp ⅝	297	337,5	61	58,5	20°	
AE 1F 1603-ID	Rp ⅝	364	71,5	Rp ¼	375,5	68,5	Rp ⅝	Rp ⅝	364	406	71,5	69	22°	

⊕Screw hole DIN 3852, shape Z

- ▶ Standard supply
- ▶ Possible supply, for these purposes, the sealing housing must be turned in case of designs P02/P12, G0S/G1S, G0T/G1T, G0Q/G1Q, G0D/G1D.

Driving possibilities

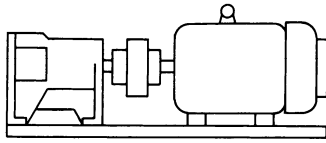

1 AE-ID with flexible coupling and motor

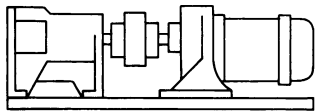

2 AE-ID with flexible coupling and geared motor

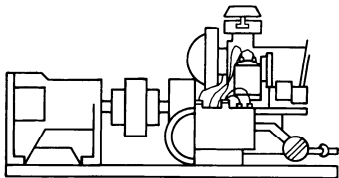

3 AE-ID with flexible coupling and combustion engine

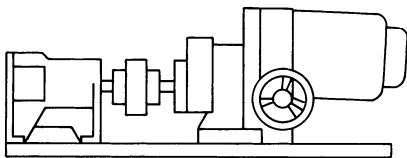

6 AE-ID with flexible coupling and infinitely variable gear

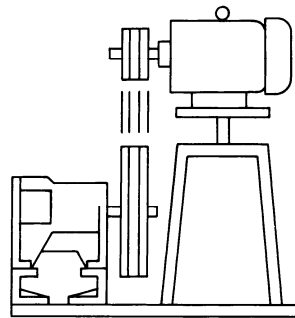

4 AE-ID with V-belt drive, rocker and motor arranged behind the pump

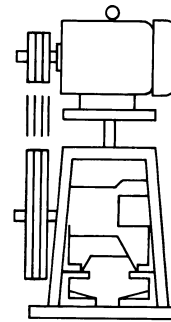

5 AE-ID with V-belt drive rocker and motor, arranged above the pump

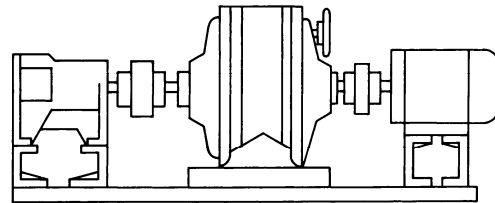

7 AE-ID with flexible coupling, gear or variable speed gear, flexible coupling and motor

Further driving variants (e.g. hydraulic or pneumatic drives) are possible.

Range of eccentric screw pumps	Series	Number of stages	Maximum capacity at $\Delta p = 0$ bar		Maximum discharge pressure bar	Maximum viscosity mPa s
			m ³ /h	l/min		
	AE1F	1	228	3800	6	300.000
	AEB1F	1	228	3800	6(4)	300.000
	AE.E-ID	1,2	450	7500	10	300.000
	AE.N-ID	1,2	290	4850	16	270.000
	AE.H-ID	2,4	174	2900	24	270.000
	AEB.E-IE	1,2	174	2900	6	300.000
	AEB.N-IE	1,2	111	1850	12	270.000
	AEB4H-IE	4	12	200	24	270.000
	AED.E-ID	1	720	12000	8	250.000
	AED.N-ID	2	450	7500	16	225.000
	AEDB.E-IE	1	258	4300	6	250.000
	AEDB.N-IE	2	174	2900	12	225.000
	AE.N...-RG	1,2,4	30	500	20	1.000.000
	TECFLOW	1	186	3100	4	200.000
	SEZP	1,2	21	350	10	1.000.000
	SNZP	1,2	45	750	12	1.000.000
	SSP	1,2	48	800	12	150.000
	SSBP	1,2	48	800	12	150.000
	SETP ①	1,2	140	2350	10	300.000
	SETBP	1,2	40	670	10	150.000
	SEFBP	1	40	670	6	150.000
	SMP	1	40	670	6	150.000
	SMP2	1	5,5	92	6	11.500
	AFP	1	2,8	47	6	50.000
	ANP	2	2,5	42	12	20.000
	ANBP	2	2,5	42	12	20.000
	ASP	2	2,5	42	12	20.000
	ASBP	2	2,5	42	12	20.000
	ADP	3	0,6	10	12	20.000
	ADBP	3	0,6	10	12	20.000
	ACNP	1,2	29	480	12	150.000
	ACNBP	1,2	29	480	12	150.000

① Special versions for higher pressures available

Peristaltic range	Series	Maximum capacity		Maximum discharge pressure bar	Maximum viscosity mPa s
		m ³ /h	l/min		
	ASL	2,4	40	4	100.000
	ASH	60	1000	15	100.000

Macerator range	Series	Maximum throughput	Static pressure head
		m ³ /h	m
	AM...S-1	80 at 3% solids	3
	ABM...S-1	80 at 3% solids	3
	AM...I-1	160 at 3% solids	-
	ABM...I-1	80 at 3% solids	-

- Accessories**
- Pump accessories: Stator setting devices, electrical heaters, bridge breakers.
 - Drivers: Electric motors, geared motors, variable speed transmissions, reduction gearboxes, internal combustion engines, pneumatic and hydraulic drives.
 - Transmission components: Couplings, V-belt transmissions, toothed belt transmissions, other types of transmission.
 - Base plates: Standard and special versions, wheeled trolleys, mounting flanges.
 - Safety arrangements: Bypass lines with safety or regulating valves, systems to guard against dry running (conductive, capacitive, thermal etc.).
 - Other accessories: Electrical, hydraulic and pneumatic control arrangements, filter systems, metering equipment, seal liquid and circulating systems for shaft seals, valves, flanges, flexible pipes.

Subject to technical alterations.